

# TOYO ED MOTOR

EDモータ (IPM同期モータ) / 水冷式EDモータ

ED Motor (IPM Synchronous Motor) / Water-cooled ED Motor

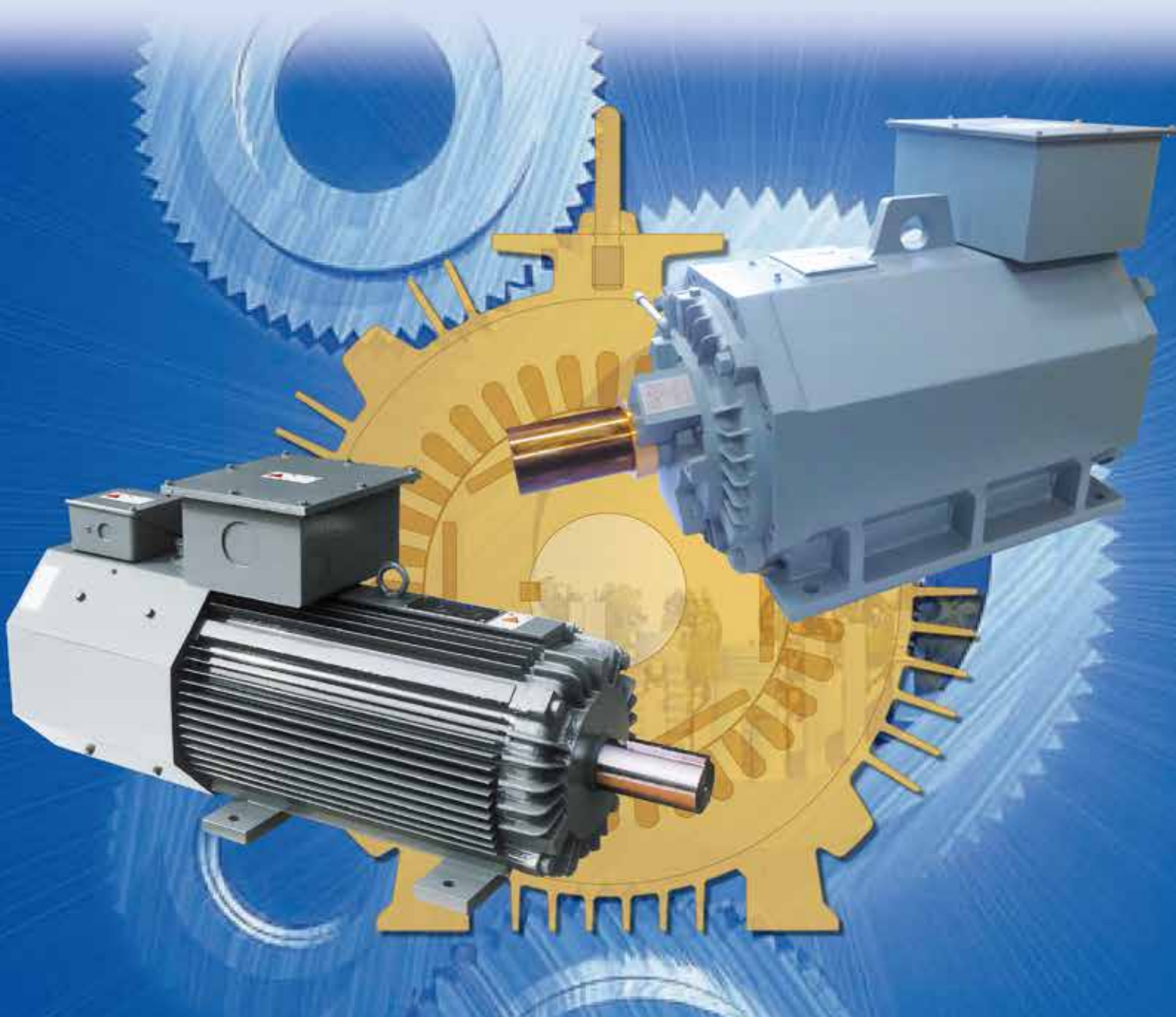

# TOYO ED MOTOR

ED MOTOR(Eco-Drive Motor)は、超高効率と小型化を実現し、経済的で (Economical) 環境にやさしい (Ecological) ドライブシステムです。

ED MOTOR(Eco-Drive Motor) is the Economical & Ecological Drive System that realizes ultra-high efficiency and down sizing.

■回転子の損失がほぼゼロ!です。  
Loss of rotor is nearly "Zero".

永久磁石埋め込み構造で二次巻線がないため、損失を低く抑えられます。

The loss can be suppressed due to no 2ndary winding in the embedded permanent magnet structure.

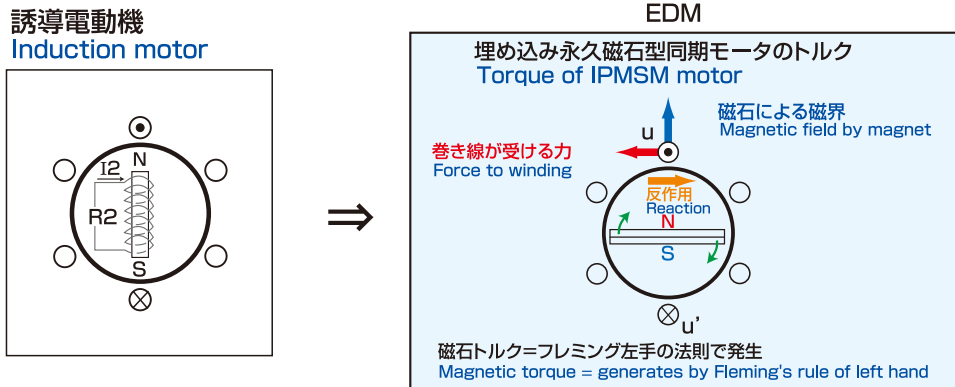

電動機の損失は半分です。(対誘導電動機)

Loss of motor is reduced to half. (as against induction motor)

110kW 1800min<sup>-1</sup>の例  
Example of 110kW, 1800min<sup>-1</sup>

誘導電動機損失  
Loss of induction motor

7.81kW

EDM損失  
Loss of EDM

4.62kW

■EDモータの効率はIE3\*を上回り大幅な省エネが期待できます。  
The efficiency of ED motor is higher than IE3\* and can expect large energy saving.

\*IE3...プレミアム効率規格値

\*IE3...Premium Standard value.

速度100%、負荷率75%、稼働率80%、15円/kWh

Speed 100%, Load factor 75%, Rate of operation 80% ¥15/kWh

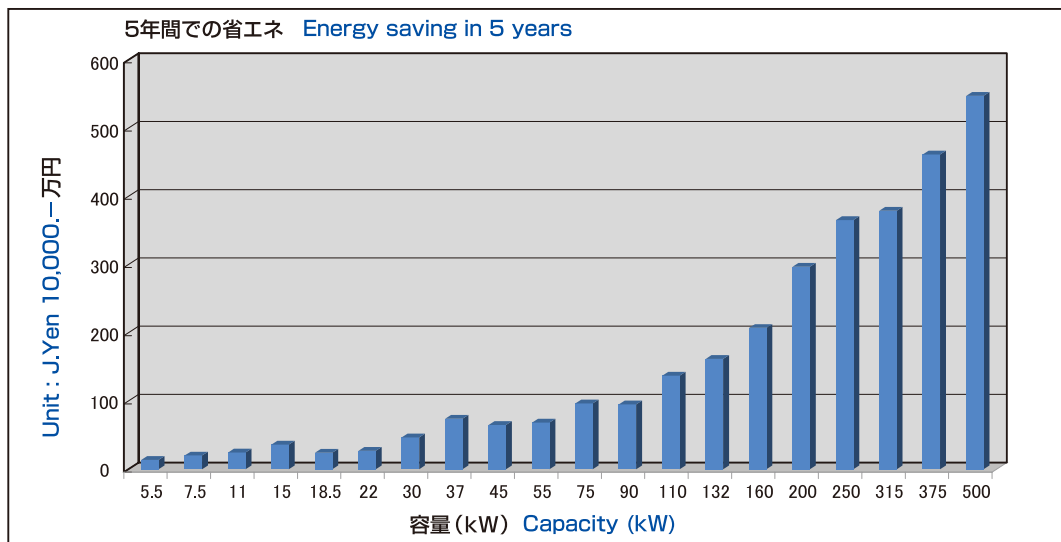

■小型・軽量です。

Small in size and light in weight.

機械の構造設計にも余裕が生まれます。

Rooms can be formed in the structure-designing of machinery

110kW 1800min<sup>-1</sup>の例  
Example of 110kW, 1800min<sup>-1</sup>

外観  
体積比:54%減  
External appearance  
Volume ratio : 54% less

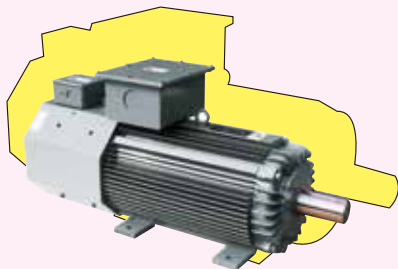

質量  
質量比:56%減  
Weight  
Weight ratio : 56% less

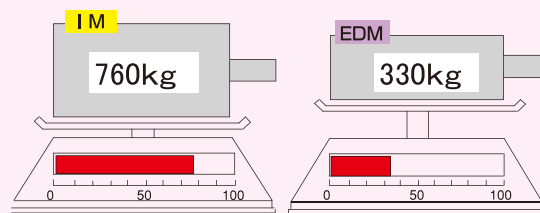

■ベアリング寿命が約2倍に!

Life of bearing is doubled!

回転子損失が非常に少ない為ベアリングの温度が低く保たれ寿命が延びます。

Bearing temperature is low as a result of very small loss of rotor.

グリース封入型グリース寿命の例  
Example of life of grease-sealed type grease

誘導電動機  
ベアリング寿命  
Induction motor  
Bearing life



EDM  
ベアリング寿命  
EDM  
Bearing life



■速度センサレスでも驚異の速度精度

It has remarkable speed accuracy in spite of speed sensorless

センサ付 Sensor mode

- ☆ ±0.01% (定格回転速度において)  
±0.01% (at the rated speed)
- ☆ 1:1000 (速度制御範囲)  
1:1000 (speed control range)

センサレス Sensorless mode

- ☆ ±0.01% (定格回転速度において)  
±0.01% (at the rated speed)
- ☆ 1:100 (速度制御範囲)  
1:100 (speed control range)

■高速応答(センサ付)

High speed response(sensor mode)

- ☆ 速度制御応答 400rad/s (-3dB)  
Speed control response 400rad/sec(-3dB)
- ☆ トルク制御応答 2krad/s (-3dB)  
Torque control response 2krad/sec(-3dB)

## 1 特長 FEATURE

### 1. 高効率

EDモータ単体での効率は、IE3プレミアム効率規格値に対して2%前後、インバータ専用IMに対して約5%前後効率UPを実現しています。

効率比較 Efficiency comparison

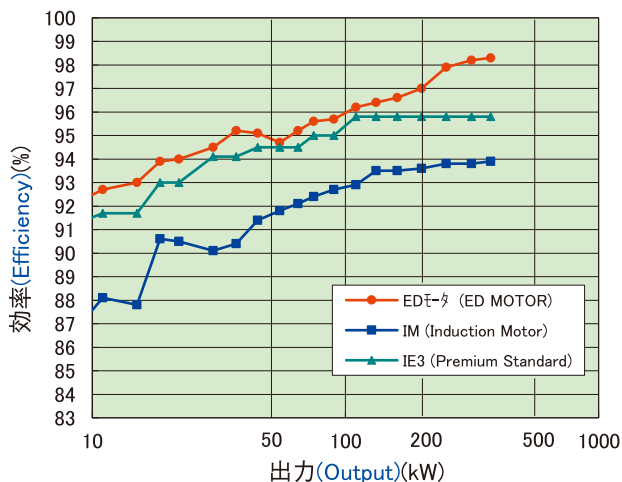

### 1. High efficiency

Efficiency of ED motor is about 2% higher than IE3 Premium Standard values of high efficiency motor. Also, ED motor realized about 5% higher efficiency than that of Induction Motor of exclusive use for Inverter.

110kW/ED UF 総合効率比較 Comparison of total efficiency

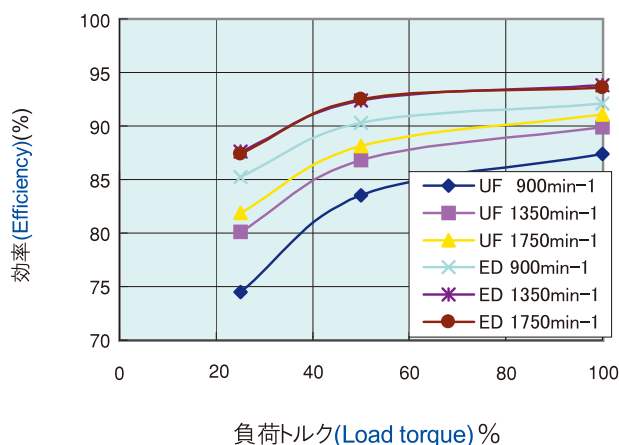

### 2. 小型軽量

当社UFシリーズインバータ専用IMに対して、同一出力比較でセンターハイトを2枠下げています。又、モータ質量も大幅に軽減されています。(当社UFシリーズインバータ専用IMに対して32~57%軽減)

センターハイト比較 Comparison of center height

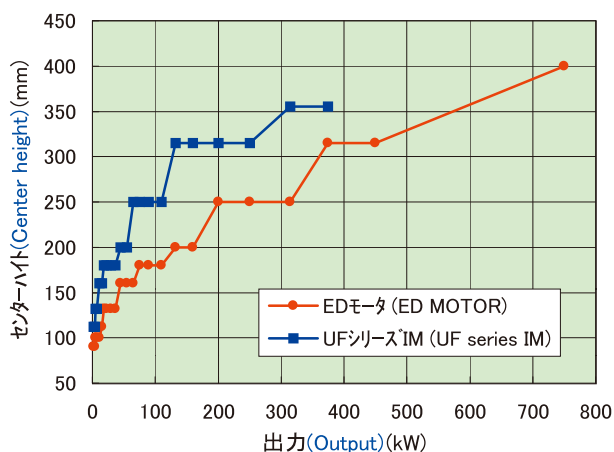

### 2. Small size and light in weight

Compared with our UF series IM of exclusive use for Inverter, center height of ED motor is about 2 divisional lines lower than that of UF series IM and also, weight of ED motor is reduced drastically by (32~57% for our UF series IM) as shown in the relevant graphs below.

質量比較 Comparison of mass

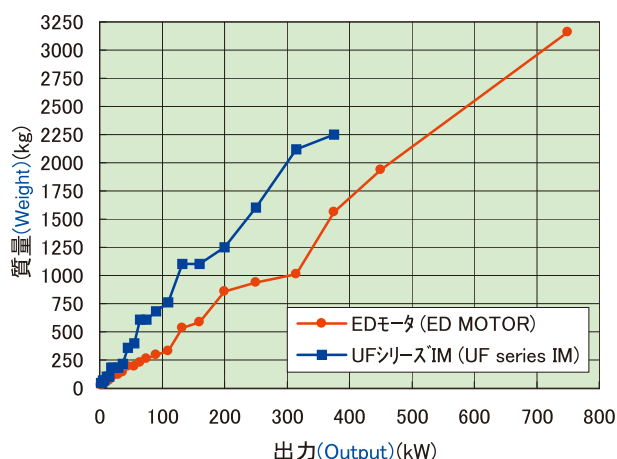

### 3. 低騒音

モータの総損失低減によりモータの冷却風量を低減し、当社UFシリーズインバータ専用IMよりも低騒音化を実現しました。

### 3. Low noise

By reduction of total loss of motor, cooling air volume of motor was reduced and lower noise level than that of UF series motor of exclusive use for Inverter was realized.

### 4. 低慣性

慣性モーメントが小さく、加減速特性に優れています。(当社UFシリーズインバータ専用IMの30~75%低減)

### 4. Low inertia

Inertia moment of ED motor is small. ED motor is excellent in accel/decel characteristics (reduced by 30~75% for our UF series IM of exclusive use for Inverter).

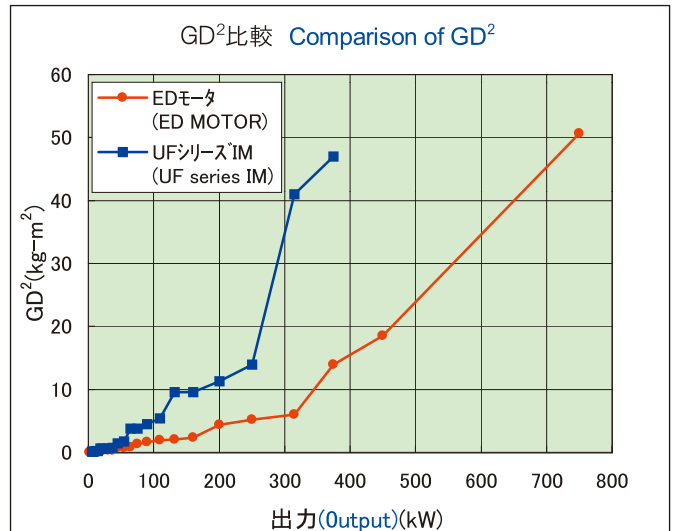
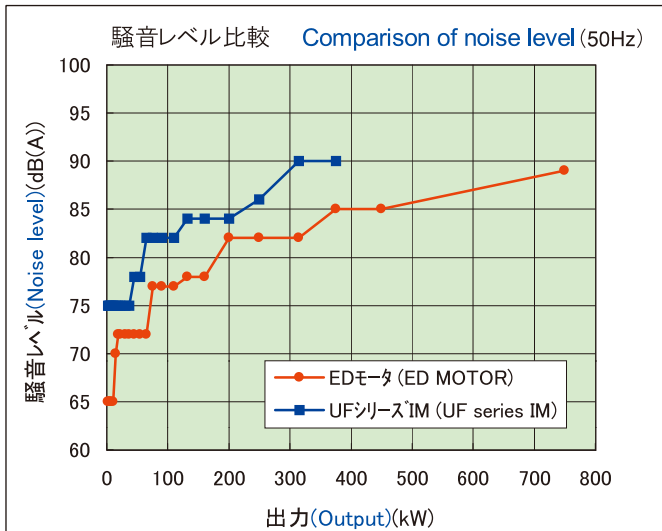

### 5. 保守の軽減

回転子側の損失がほとんど発生しないので軸受部の温度が低く、封入グリース寿命は当社UFシリーズインバータ専用IMに対して約1.5~2倍(約32,000~47,000Hr)になり、保守作業を軽減できます。

### 5. Lightening of maintenance work

Since loss of rotor side occurs scarcely, temperature of bearing part is low and life of enclosed grease is about 1.5 - 2 times (about 32,000~47,000 hrs) of that of UF series IM of exclusive use for Inverter. Thus, maintenance work can be lightened.

### 7. 省エネ計算

次のグラフは[EDモータ+INV]の組み合わせによる総合効率と[誘導電動機(IM)+INV]、[直流電動機(DM)+レオナード装置]による総合効率の差から省エネ電力を表したものです。

モータ容量から省エネ電力Ps[kW]を求め、次式にて省エネ金額を求めることができます。

$$\text{年間省エネ金額 [円]} = Ps [\text{kW}] \times \text{年間運転時間 [H]} \times \text{電力単位 [円/kWh]}$$

$$\text{Annual energy saving amount [¥]} = Ps [\text{kW}] \times \text{Annual operating time [H]} \times \text{Unit price of power [¥/kWh]}$$

[例] 200 kWにて直流電動機との比較(75%速度・75%トルクの場合)

$$\text{年間省エネ金額} = 8.5 \text{ kW} \times (24 \text{ h} \times 300 \text{ 日}) \times 15 \text{ 円/kWh} = 918,000 \text{ 円}$$

[Example] Comparison with DC motor at 200kW (In case of 75% speed, 75% torque)

$$\text{Annual energy saving amount} = 8.5 \text{ kW} \times (24 \text{ h} \times 300 \text{ days}) \times 15 \text{ ¥/kWh} = 918,000.$$

### 6. 高性能ベクトルインバータ

永久磁石モータを制御する専用インバータには革新的なHC機能・シーケンス機能・トレースバック機能を装備し、フレキシブルな制御を構成することが可能です。

### 6. High performance vector Inverter

In the Inverter which controls permanent magnet motor exclusively, innovative HC function, sequence function, trace back function are incorporated and by these functions, flexible control can be structured.

### 7. Calculation of energy saving

Graphs shown below indicate the power of energy saving, obtained from difference between overall efficiency by combination of [ED motor + INV] and overall efficiency by [Induction motor (IM) + INV], [DC motor (DM) + SCR equipment].

Find the energy saving power Ps[kW] from motor capacity. After that, energy saving amount can be found by the under-mentioned equation.

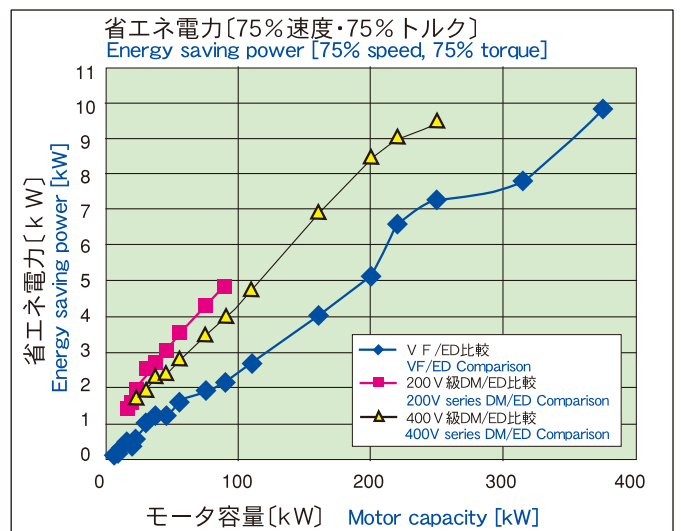
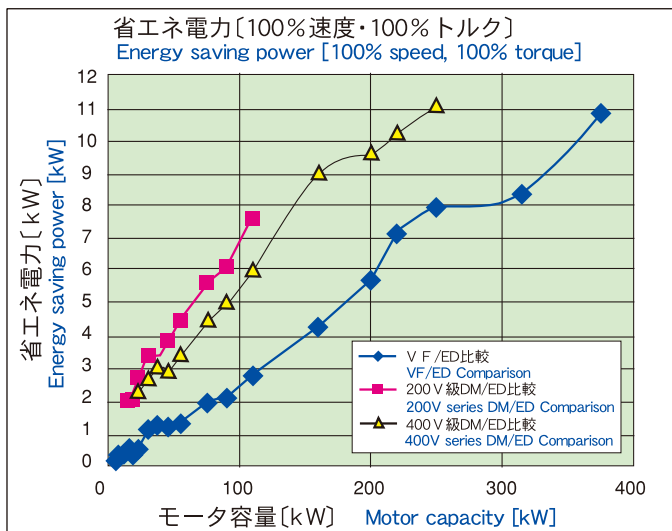

## 2 東洋EDモータ TOYO ED MOTOR

### 1) 標準仕様 Standard Specifications

		標準仕様 Standard	準標準仕様 Available on Request	
1	定格事項 Rating	極数 No. of pole 出力 Output	6極 6 Poles (190V級は90kWまで) 1.5~750kW (190V class is up to 90kW)	
		電圧 Voltage	190/380V	
		定格基底回転速度 Rated Rotating speed 時間定格 Time rating	1800min <sup>-1</sup> 出力一定範囲は基底回転に対し1:1.33 Output constant range is 1:1.33 against basic rotating speed. 連続 Continuous	1500min <sup>-1</sup> /1200min <sup>-1</sup> 回転速度、定出力範囲の変更についてはお問い合わせ下さい。 Please refer to us for change of rotation speed or power constant range.
2	外被 Enclosure	保護形式 Protection	IP44(全閉防まつ形) IP44(Totally enclosed splash proof)	IC411(外被表面冷却自力形) IC411(Surface self cooling)
		冷却 Cooling	IC416(外被表面冷却・他力形) IC416(Surface forced cooling)	
3	絶縁の種類 Insulation		F種 class F、H種 class H …750kWのみ only 750kW	
	温度上昇 Temp. rise		F種、又はB種ライズ F or B rise H種ライズ H rise …750kWのみ only 750kW	
4	使用環境 Environment	周囲温度 Ambient temp	-10~+40°C	+40~+60°C, -10~-30°C
		相対湿度 Relative humidity	95%RH以下 less than 95%RH	95%超過 Over 95%RH
		標高 Altitude	1000m以下 less than 1000m	1000m超過 Over 1000m
		使用場所 Installation place	屋内 Indoor	
	ガス・蒸気 Gas, vapor	有害な腐食性、爆発性のガスや蒸気の無い 屋内場所 Indoor without hazardous gases, such as corrosive or explosive gases	防食2種、3種 Corrosion proof class 2, class 3	
5	取付方式 Mounting	横据置脚取付け(B3) Foot mounting(B3) ギヤードモータ Geared Motors. 1.5kW~55kW	フランジ形、立て形 See "Mounting arrangement."	
6	負荷との結合 Coupling method	直結/ベルト掛 (ベルト掛けは250kWまで) Direct coupling/Belt driving (Up to 250kW in case of belt driving)		
7	振動 Class of vibration	両振幅V30以下 Less than V30: Full-amplitude(Peak to peak)	両振幅V10以下 V10: and less	
8	騒音レベル Noise level	枠番・Frame size…………dB(A) 50/60Hz 90……………65/67 dB(A) 100……………65/67 dB(A) 112……………70/72 dB(A) 132……………75/78 dB(A) 160……………75/78 dB(A) 180……………77/80 dB(A) 200……………78/81 dB(A) 250……………82/85 dB(A) 315……………85/88 dB(A) 400……………89/93 dB(A)		
9	始動トルク Starting torque	150% 150% of Full load	150%超過・未滿 150% over or 150% under	
10	超過トルク耐量 Momentary excess torque	150% 1分間 150% of Full load, 1min.	150%超過・未滿 150% over or 150% under	
11	附属品 Accessories	電動送風機、オプトコーダ PTCサーミスタ素子 Independent electric cooling fan, Optcoder PTC thermistor element	ブレーキ(無励磁作動型)付 減速機(ギヤード)等 Electromagnetic brake Reduction gear ……etc.	
12	塗色 Painting Color	マンセル 7.5 BG 4/1.5 Munsell 7.5 BG 4/1.5		
13	適用規格 Apprication Standard	JEC-2100		

## 2) 出力・枠番適用・定格電流

### Application Between Output(kW),Rotating Speed(min<sup>-1</sup>)&Frame Size, Full Load Current(A)

	標準仕様 Standard		標準仕様 Available on Request			
	190V	380V	190V	380V	190V	380V
出力一定速度 Power constant speed	2400~1800min <sup>-1</sup>		2000~1500min <sup>-1</sup>		1600~1200min <sup>-1</sup>	
トルク一定範囲 Torque constant range	1800~0min <sup>-1</sup>		1500~0min <sup>-1</sup>		1200~0min <sup>-1</sup>	
基底速度 Base speed	1800min <sup>-1</sup>		1500min <sup>-1</sup>		1200min <sup>-1</sup>	
定格出力 Rated output	190V		380V		190V	
定格電圧 Rated voltage	380V		190V		380V	
1.5kW	90A EDM1311V* 5.2A/6.7A	2.6A/3.3A	90A EDM1311V 5.3A/6.1A	2.7A/3.0A	90A EDM1311V 5.3A/6.2A	2.6A/3.1A
2.2kW	90A EDM1311V* 7.6A/9.1A	3.8A/4.5A	90A EDM1321V 7.7A/8.8A	3.8A/4.6A	90A EDM1321V 7.7A/9.0A	3.8A/4.5A
3.7kW	90A EDM1321V* 12.5A/15.9A	6.2A/7.9A	100A EDM1711V 15.1A/13.5A	7.6A/6.7A	100A EDM1711V 14.3A/13.6A	6.9A/6.7A
5.5kW	100A EDM1711V 20.8A/19.8A	10.4A/9.9A	100A EDM1711V 19.5A/20.0A	9.8A/9.9A	100B EDM1721V 21.3A/19.4A	10.7A/9.7A
7.5kW	100A EDM1711V 25.9A/27.2A	13.0A/13.5A	100B EDM1721V 28.3A/26.3A	14.3A/13.1A	112A EDM1921V 26.4A/27.0A	13.2A/13.6A
11kW	100B EDM1721V 38.0A/39.4A	19.0A/19.6A	112A EDM1921V 36.2A/42.2A	18.1A/21.1A	112B EDM1931V 37.5A/41.0A	19.0A/20.1A
15kW	112A EDM1921V 50.2A/60.8A	24.9A/27.5A	112B EDM1931V 51.2A/53.6A	24.5A/29.6A	112B EDM1931V 49.8A/56.4A	25.0A/27.9A
18.5kW	112B EDM1931V 61.6A/68.4A	30.8A/34.0A	112B EDM1931V 61.5A/67.2A	30.8A/36.8A	132A EDM2221V 62.9A/65.9A	31.5A/32.8A
22kW	112B EDM1931V 72.4A/81.7A	36.2A/40.6A	132A EDM2221V 74.1A/79.4A	37.1A/39.5A	132B EDM2231V 72.7A/80.9A	36.4A/40.3A
30kW	132A EDM2221V 97.9A/114A	48.9A/56.8A	132B EDM2231V 98.9A/110A	49.2A/54.5A	160A EDM2761V 95.9A/117A	47.9A/58.2A
37kW	132B EDM2231V 121A/134A	60.6A/66.8A	160A EDM2761V 119A/146A	59.7A/68.1A	160A EDM2761V 119A/143A	59.3A/71.2A
45kW	160A EDM2761V 146A/164A	72.6A/81.9A	160A EDM2761V 144A/175A	71.9A/83.5A	160A EDM2761V 144A/169A	71.8A/84.1A
55kW	160A EDM2761V 176A/202A	88.0A/101A	160A EDM2761V 176A/202A	88.0A/101A	160B-2 EDM2781V 176A/198A	88.1A/98.7A
75kW	160B-1 EDM2772V 240A/270A	120A/135A	160B-2 EDM2781V 239A/280A	119A/140A	180A EDM3141V 239A/269A	119A/134A
90kW	160B-2 EDM2781V 287A/325A	143A/162A	180A EDM3141V 286A/322A	143A/161A	180B-1 EDM3151V 286A/340A	143A/177A
110kW	180A EDM3141V —	175A/203A	180B-1 EDM3151V —	174A/197A	180B-2 EDM3161V —	174A/196A
132kW	180B-1 EDM3151V☆ —	210A/253A	180B-2 EDM3161V —	209A/240A	200A EDM3541V —	208A/235A
160kW	同上	同上	同上	同上	200B EDM3551V —	210A/238A
	180B-2 EDM3161V☆ —	294A	200B EDM3551V —	258A/278A	200B EDM3551V —	252A/290A
200kW	同上	同上	同上	同上	200B EDM3561V —	314A/367A
	200B EDM3551V☆ —	366A	200B EDM3561V —	328A/336A	200B EDM3561V —	250A-1 EDM4331V 312A/354A
250kW	200B EDM3561V☆ —	441A	250A-1 EDM4331V —	393A/451A	250A-1 EDM4331V —	392A/422A
315kW	250A-2 EDM4332V* —	599A	315A-2 EDM5422V* —	493A/581A	315A-1 EDM5411V —	489A/598A
375kW	315A-2 EDM5412V* —	600A	315A-2 EDM5422V★ —	590/688A	315A-1 EDM5451V —	597A/652A
400kW	—	—	—	—	315A-1 EDM5451V —	631A/696A
450kW	315A-2 EDM5452V* —	707A	315A-2 EDM5462V★ —	700/781A	315A-2 EDM5462V★ —	701A/840A
750kW	—	—	—	—	400A EDM6851V* —	1260A

注1) EDM13形は自己冷却式も製作できます。自己冷却式の型式はEDM13\*\*Fとなります。また、この場合の変速範囲は1:20で、低速での負荷低減が必要となります。(9ページの低減特性参照)

注2) 315kW 375kW 450kW、及び750kWの内、\*印はトルコン制御のみとなります。但し、750kWは700kWに容量低減すればパワコン範囲1500~1200min<sup>-1</sup>にて適用可能です。(700kW 1500/1200min<sup>-1</sup> 1101/1170A)

注3) 375kW 1600~1200min<sup>-1</sup>を1200min<sup>-1</sup>のトルコン制御のみにて使用する場合には、枠番EDM5431V(593A)でも製作可能です。

注4) 375kW、及び450kW、基底速度1500min<sup>-1</sup>のパワコン範囲は1800~1500min<sup>-1</sup>となります。又、450kW、基底速度1200min<sup>-1</sup>のパワコン範囲は1500~1200min<sup>-1</sup>となります。(★印)

注5) 132kW、160kW、200kW、及び250kWの内、☆印はトルコン制御のみとなります。パワコン制御が必要な場合は各々枠番が一枠大きくなり、132kW EDM3161V(210/247A)、160kW EDM3511V(253/297A)、200kW EDM3561V(315/352A)、250kW EDM4332V(395A/460A)となります。

注6) 部(132~200kW 1200min<sup>-1</sup>ベースはセンサレス適用時の枠番)

Note 1) The EDM13 type can produce the self-cooling type. In this case, the model become EDM13\*\*F, variable speed range becomes 1:20 and load derating at low speed is needed. (Refer to derating factor of P.9)

Note 2) \* of 315kW 375kW, 450kW and 750kW is only torque constant. However, if 750kW decreases to 700kW, it can be applied within power constant range of 1500-1200min<sup>-1</sup>. (700kW 1500/1200min<sup>-1</sup> 1101/1170A)

Note 3) In case that 375kW 1600-1200min<sup>-1</sup> is used by torque constant only of 1200min<sup>-1</sup>, frame size EDM5431V(593A) can also be used.

Note 4) Power constant control range of base speed 1500min<sup>-1</sup> of 375kW and 450kW becomes 1800-1500min<sup>-1</sup>. And power constant range of base speed 1200min<sup>-1</sup> of 450kW becomes 1500-1200min<sup>-1</sup>. (★sign)

Note 5) Among 132kW, 160kW, 200kW and 250kW, ☆marked type is torque constant control only. In case that power constant is needed one rank larger frame types are used respectively, i.e., 132kW EDM3161V(210/247A), 160kW EDM3551V(253/297A), 200kW EDM3561V(315/352A), 250kW EDM4332V(395/460A).

Note 6) For sensorless mode operation, the motors in screened column (132~200kW, Base speed: 1200min<sup>-1</sup>) are to be applied.

## 3) 外形寸法 (脚取付形) Dimensions (Foot mounting)

形式・Type 枠番 Frame Size	図・番号 Fig. Symbol	電動機本体 General (mm)																	
		C	D	E	F	G	H	J	K1	K2	K3	L	M	N	R	XB	Z	KD	
EDM1311F 90A	A	90 <sub>±0.5</sub>	185	70	62.5	12	247	-	38	38	19	459.5	180	163	178.5	56	10	22	
EDM1321F 90A		90 <sub>±0.5</sub>	185	70	62.5	12	247	-	38	38	19	459.5	180	163	178.5	56	10	22	
EDM1311V 90A		90 <sub>±0.5</sub>	185	70	62.5	12	247	-	38	38	19	510	180	163	178.5	56	10	22	
EDM1321V 90A		90 <sub>±0.5</sub>	185	70	62.5	12	247	-	38	38	19	510	180	163	178.5	56	10	22	
EDM1711V 100A		100 <sub>±0.5</sub>	225	95	79.5	12	304	-	38	38	19	563	220	197	222.5	63	12	35	
EDM1721V 100B		100 <sub>±0.5</sub>	225	95	79.5	12	304	-	38	38	19	663	220	197	278.5	89	12	35	
EDM1921V 112A		112 <sub>±0.5</sub>	249	108	101.5	12	322	-	38	38	19	674	250	241	300.5	89	12	35	
EDM1931V 112B		112 <sub>±0.5</sub>	249	108	101.5	12	352	-	38	38	19	674	250	241	300.5	89	12	51	
EDM2221V 132A		132 <sub>±0.5</sub>	283	127	127	17	393	-	65	65	32.5	794.5	300	319	345	108	14.5	51	
EDM2231V 132B		132 <sub>±0.5</sub>	283	127	139.5	17	393	-	65	65	32.5	834.5	300	344	357.5	108	14.5	51	
EDM2761V 160A		B	160 <sub>±0.5</sub>	333	139.5	159	20	447	70	85	85	42.5	944	350	403	467	168	18.5	64
EDM2771V 160A			160 <sub>±0.5</sub>	333	139.5	159	20	447	70	85	85	42.5	944	350	403	467	168	18.5	64
EDM2772V 160B-1	160 <sub>±0.5</sub>		355	139.5	159	20	488	70	85	85	42.5	971	350	403	467	168	18.5	80	
EDM2781V 160B-2	160 <sub>±0.5</sub>		355	139.5	159	20	488	70	85	85	42.5	1014	350	403	467	168	18.5	80	
EDM3141V 180A	180 <sub>±0.5</sub>		375	159	203	20	531	105	100	100	50	1061	370	506	511	168	24	80	
EDM3151V 180B-1	180 <sub>±0.5</sub>		375	159	203	20	531	105	100	100	50	1116	370	506	581	208	24	80	
EDM3161V 180B-2	180 <sub>±0.5</sub>		375	159	203	20	531	105	100	100	50	1196	370	506	581	208	24	80	
EDM3541V 200A	200 <sub>±0.5</sub>		444	203	254	32	593	100	114	114	50	1343	460	608	592	168	24	80	
EDM3551V 200B	200 <sub>±0.5</sub>		444	228.5	315	32	593	135	120	120	50	1445	520	730	715	225	28	80	
EDM3561V 200B	200 <sub>±0.5</sub>		489.5	228.5	315	32	643	135	120	120	50	1445	520	730	715	225	28	102	
EDM4331V 250A-1	250 <sub>±0.5</sub>		547	228.5	315	32	733	100	120	120	50	1481	520	730	715	225	28	102	
EDM4332V 250A-2	250 <sub>±0.5</sub>		547	228.5	315	32	733	100	120	120	50	1561	520	730	715	225	28	102	
EDM5411V 315A-1	C	315 <sub>±0.1</sub>	679	305	355	32	884	110	130	130	55	1781	680	820	781	251	28	-	
EDM5431V 315A-1		315 <sub>±0.1</sub>	679	305	355	32	884	110	130	130	55	1781	680	820	781	251	28	-	
EDM5451V 315A-1		315 <sub>±0.1</sub>	679	305	355	32	884	110	130	130	55	1781	680	820	781	251	28	-	
EDM5412V 315A-2		315 <sub>±0.1</sub>	679	305	355	32	884	110	130	130	55	1821	680	820	781	251	28	-	
EDM5422V 315A-2		315 <sub>±0.1</sub>	679	305	355	32	884	110	130	130	55	1821	680	820	781	251	28	-	
EDM5452V 315A-2		315 <sub>±0.1</sub>	679	305	355	32	1275	110	130	130	55	2034	680	820	781	251	28	-	
EDM5462V 315A-2	D	315 <sub>±0.1</sub>	679	305	355	32	1275	110	130	130	55	2034	680	820	781	251	28	-	
EDM6851V 400A		E	400 <sub>±0.1</sub>	830	375	450	38	1524	180	140	140	70	2073	830	1040	940	280	35	-

1. 寸法を変更する場合があります。ご注文の際には改めてご承認用寸法図を提出いたします。
2. スライドレールが必要な場合は、13頁を参照され、別途ご要求下さい。



軸端部 Shaft Extension (mm)							軸受 Bearing 伝動側 Drive End 反伝動側 Non-Drive End	概略 質量 Approx Weight (kg)	GD <sup>2</sup> Rotor Inertia (kgf-m)	電動送風機入力仕様 Independent Electric Cooling Fan Motor			
Q	QR	S	T	U	W	ED				相・極数 Phase Poles	容量 Output	周波数-電圧 Frequency -Voltage	電流 Input Current
60	0.5	28j6	7	4	8	50	6206ZZ/5K 6205ZZ/5K	25	0.023	-	-	-	-
60	0.5	28j6	7	4	8	50	6206ZZ/5K 6205ZZ/5K	30	0.026	-	-	-	-
60	0.5	28j6	7	4	8	50	6206ZZ/5K 6205ZZ/5K	26	0.011	単相2P Single phase	30W	50/60Hz 200/220V	0.33/0.33A
60	0.5	28j6	7	4	8	50	6206ZZ/5K 6205ZZ/5K	31	0.014				
80	0.5	38k6	8	5	10	56	6308ZZ/5K 6308ZZ/5K	46	0.063	単相2P Single phase	40W	50/60Hz 200/220V	0.87/0.89A
110	1.0	42k6	8	5	12	86	6309ZZ/5K 6309ZZ/5K	60	0.090				
110	1.0	42k6	8	5	12	86	6309ZZ/5K 6309ZZ/5K	60	0.066	単相2P Single phase	40W	50/60Hz 200/220V	0.87/0.89A
110	1.0	48k6	9	5.5	14	86	6311ZZ/5K 6309ZZ/5K	71	0.090				
110	1.5	55m6	10	6	16	84	6312ZZ/5K 6312ZZ/5K	121	0.29	単相2P Single phase	65W	50/60Hz 200/220V	0.85/1.0A
110	1.5	55m6	10	6	16	84	6312ZZ/5K 6312ZZ/5K	140	0.33				
140	1.0	60m6	11	7	18	110	NU313 6312ZZ/5K	185	0.46	単相2P Single phase	65W	50/60Hz 200/220V	0.85/1.0A
140	1.0	60m6	11	7	18	110	NU313 6312ZZ/5K	225	0.58				
140	1.0	75m6	12	7.5	20	110	NU316 6312ZZ/5K	235	0.62	単相2P Single phase	65W	50/60Hz 200/220V	0.85/1.0A
140	1.0	75m6	12	7.5	20	110	NU316 6312ZZ/5K	255	0.69				
140	1.0	75m6	12	7.5	20	110	NU316 6315ZZ/5K	305	1.02	3相4P Three phase	150W	50Hz 200/400V	1.1/0.55A
170	1.0	95m6	14	9	25	135	NU320 6315ZZ/5K	330	1.23				
170	1.0	95m6	14	9	25	135	NU320 6315ZZ/5K	415	1.46	3相4P Three phase	220W	60Hz 220/440V	1.2/0.6A
170	1.0	95m6	14	9	25	135	NU320 6315ZZ/5K	510	2.34				
175	-	110m6	16	10	28	165	NU324 6318	650	2.93	3相4P Three phase	270W	50Hz 200/400V	2.0/1.1A
175	-	110m6	16	10	28	165	NU324 6318	700	3.24				
175	-	110m6	16	10	28	165	NU324 6318	1010	6.04	3相4P Three phase	390W	60Hz 220/440V	2.1/1.2A
175	-	110m6	16	10	28	165	NU324 6318	1050	6.50				
175	-	110m6	16	10	28	165	6324 6318	1500	12.7	3相4P Three phase	480/750W	50/60Hz 200V	2.8/3.5A
175	-	110m6	16	10	28	165	6324 6318	1620	15.0				
175	-	110m6	16	10	28	165	6324 6318	1740	17.4	3相4P Three phase	5.5kW	50Hz 200/400V	15.5/7.8A
175	-	110m6	16	10	28	165	6324 6318	1560	13.9				
175	-	110m6	16	10	28	165	6324 6318	1620	15.0	3相4P Three phase	3.7kW	60Hz 220/440V	13.5/6.8A
175	-	110m6	16	10	28	165	6324 6318	1940	18.5				
175	-	110m6	16	10	28	165	6324 6318	2000	19.7	3相4P Three phase	5.5kW	50Hz 200/400V	21.0/10.5A
210	-	120m6	18	11	32	200	6326 6324	3160	50.6				

1.Dimension may be changed without pre-advance.At the time of order from customer,dimension drawing for approval is supplied newly.

2.In case of need of slide rail,see itim page 13 and require us.separately.

# TOYO ED MOTOR

## □ 外形寸法 (脚取付形) Dimensions (Foot mounting)

図A(90A~132B枠) Fig.A(90A~132B Frame size)

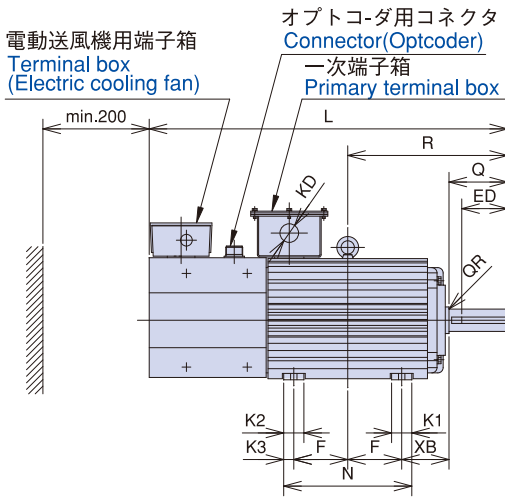

注) 90A枠 (形式EDM1311F、EDM1321F)には、電動送風機は付属しません。

Note) Blower is not attached to 90A Frame (Types EDM1311F, EDM1321F)

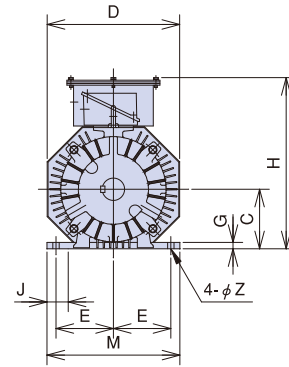

EDM1311F、EDM1321Fのトルク低減特性  
Derating factor of EDM1311F, EDM1321F

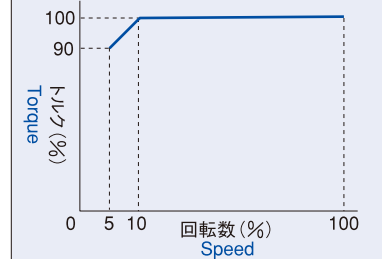

図B(160A-1~200A枠) Fig.B(160A-1~200A Frame size)

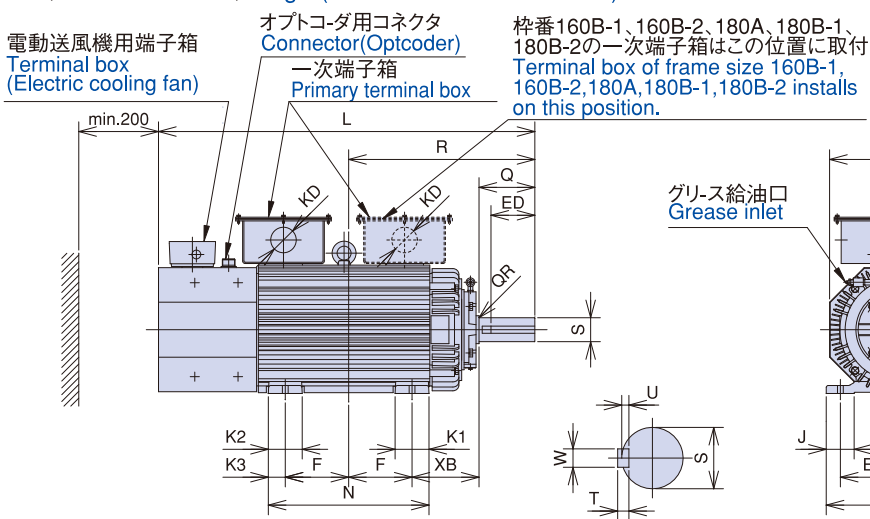

グリス給油口  
Grease inlet

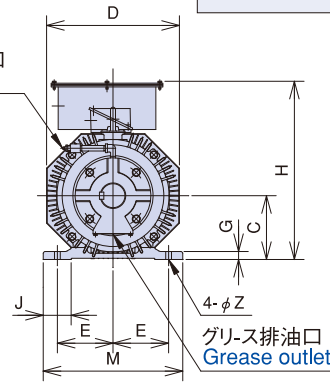

図C(200B枠~315A-2枠,形式EDM5422V) Fig.C(200B Frame size ~ 315A-2 Frame size, Type EDM5422V)

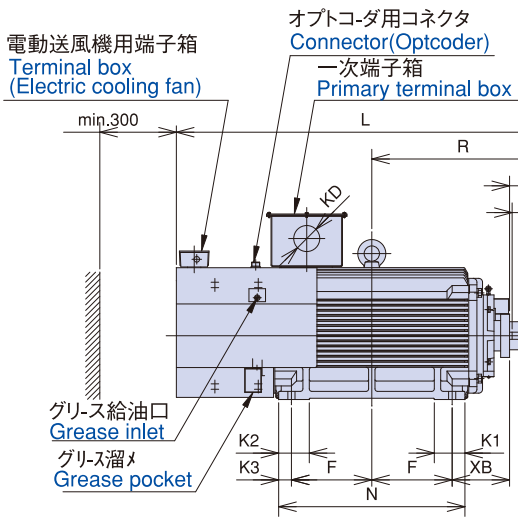

グリス給油口  
Grease inlet

アースブラシ  
Earth brush

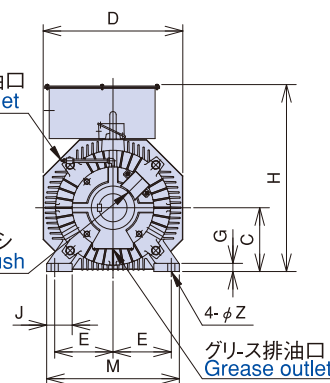

図D(315A-2枠,形式EDM5452V,EDM5462V)  
 Fig.D(315A-2 Frame size, Type EDM5452V,EDM5462V)

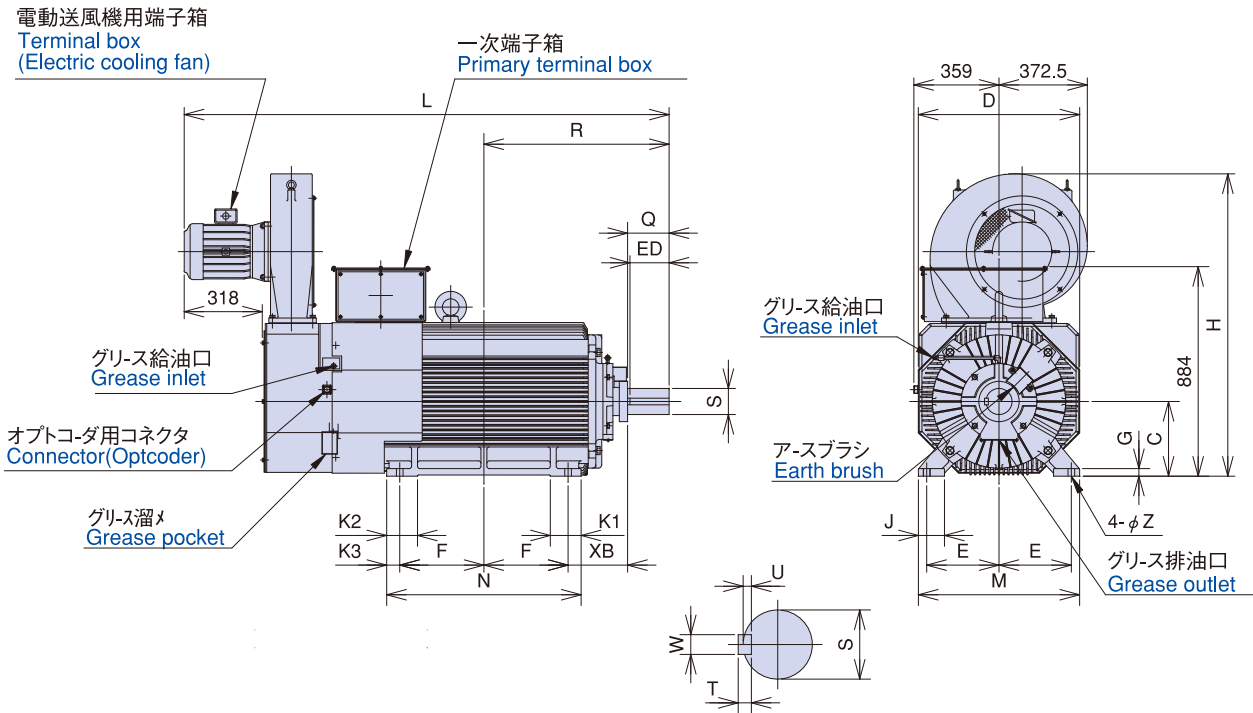

図E(400A枠) Fig.E(400A Frame size)

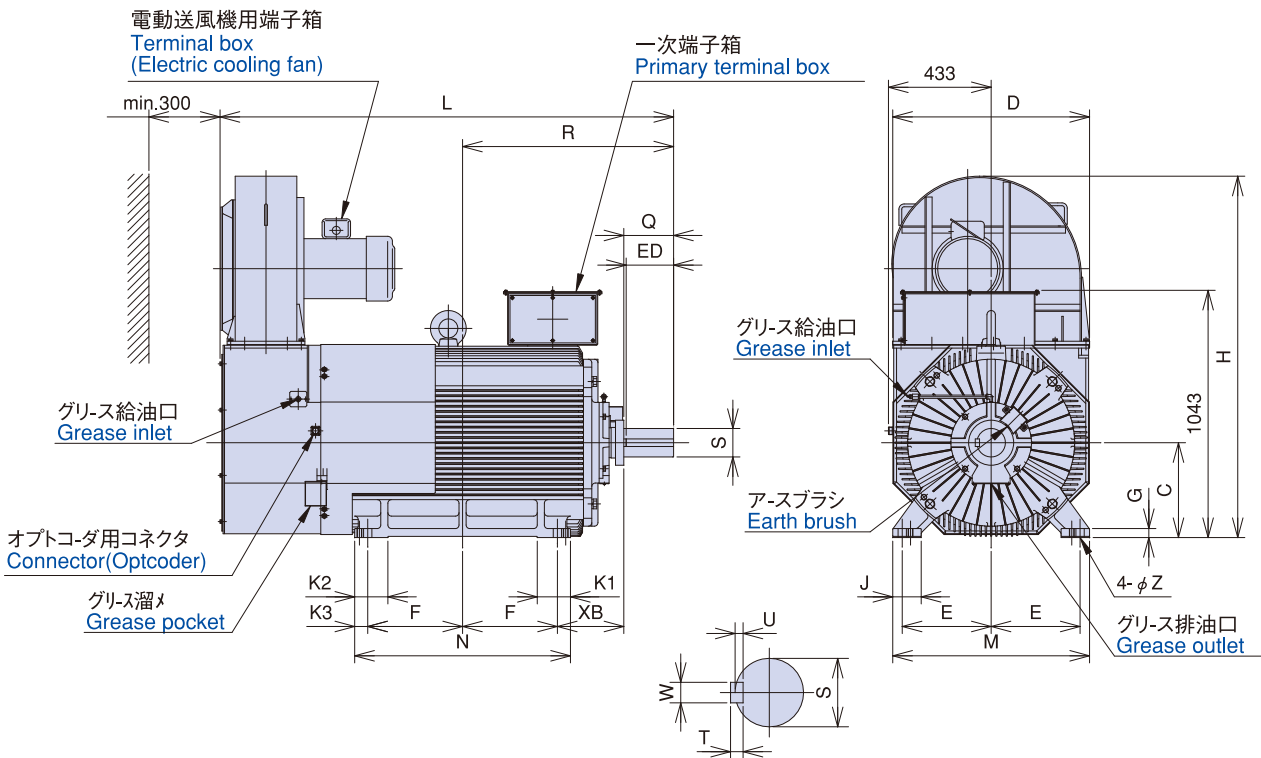

## 4) 参考事項 For Reference

### 1. オーバハングロード(軸荷重)許容値

#### Maximum Permissible External Axial and Radial Thrust Load in N

○ 横据置形  
Horizontal Shaft

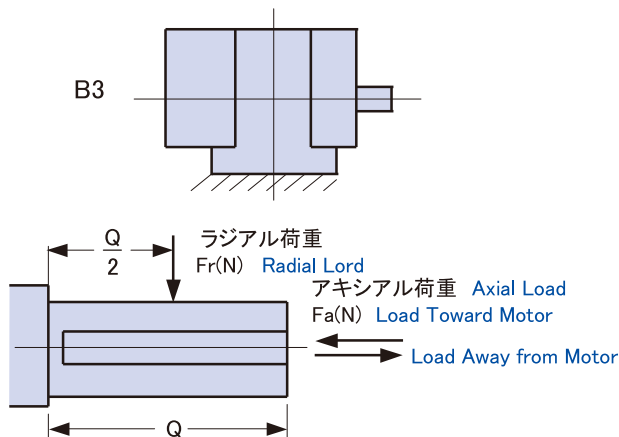

FrとFaが同時に作用しない場合の許容値を示します。  
同時に作用する場合は当社へご照会下さい。

Permissible value described in case that Fr and Fa does not work at the same time.

When Fr and Fa work both at the same time, kindly inquire us.

○ 立て軸形(軸下向)  
Vertical Shaft(Shaft Down)

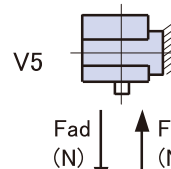

下向アキシャル荷重 Load Down Fad(N)  
上向アキシャル荷重 Load Up Fau(N)

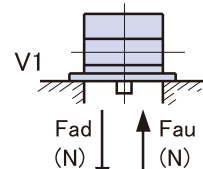

下向アキシャル荷重 Load Down Fad(N)  
上向アキシャル荷重 Load Up Fau(N)

○ 立て軸形(軸上向)  
Vertical Shaft(Shaft Up)

下向アキシャル荷重 Load Down Fad(N)  
上向アキシャル荷重 Load Up Fau(N)

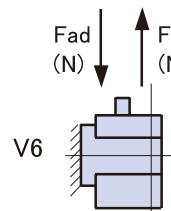

下向アキシャル荷重 Load Down Fad(N)  
上向アキシャル荷重 Load Up Fau(N)

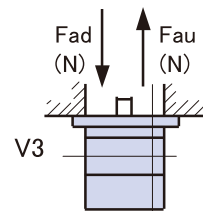

電動機 Motor			横据置形 B3 Horizontal Shaft			立て軸形(軸下向、上向とも) Vertical Shaft(Shaft Down & Up)V1,V3,V5,V6			
枠番 Frame Size	形式 Type	1800~2400min <sup>-1</sup> における出力 Output at 1800~2400min <sup>-1</sup> (kW)	ラジアル(軸直角)荷重 Radial Load Fr(N)	アキシャル(軸平行)荷重 Load Towards Motor Load Away from Motor Fa(N)		下向アキシャル(軸平行)荷重 Load Down Fad(N)		上向アキシャル(軸平行)荷重 Load Up Fau(N)	
				1800min <sup>-1</sup>	2400min <sup>-1</sup>	1800min <sup>-1</sup>	2400min <sup>-1</sup>	1800min <sup>-1</sup>	2400min <sup>-1</sup>
90A	EDM1311F	2.2	880	480	410	410	340	550	480
	EDM1311F	3.7		480	410	410	340	550	480
100A	EDM1711V	5.5	1430	1450	1250	1310	1110	1590	1390
		7.5							
100B	EDM1721V	11	1920	1840	1610	1630	1400	2050	1820
112A	EDM1921V	15							
112B	EDM1931V	18.5	3696	1840	1610	1630	1400	2050	1820
		22							
132A	EDM2221V	30	4630	2750	2390	2390	2030	3110	2750
132B	EDM2231V	37				2340	1980	3160	2800
160A	EDM2761V	45	9700	2560	2230	2070	1740	3050	2720
		55							
160B-1	EDM2772V	75	14200	2560	2230	1938	1608	3182	2852
160B-2	EDM2781V	90				1885	1555	3235	2905
180A	EDM3141V	110	14200	3480	3050	2673	2243	4287	3857
180B-1	EDM3151V	132				2427	1997	4173	3743
180B-2	EDM3161V	160	19400	3300	2870	2202	1772	4398	3968
200A	EDM3541V	132但し1200min <sup>-1</sup>	19400	3300	2870	1760	1330	4720	4290
200B	EDM3551V	200				2070	1470	5790	5190
		EDM3561V	250	1960	1360	5900	5300		
250A-1	EDM4331V	200但し1200min <sup>-1</sup>	26900	3930	3330	1530	930	6330	5730
250A-2	EDM4332V	315				1530	930	6330	5730
315A-1	EDM5411V ~ EDM5451V	315,375,400 但し1200min <sup>-1</sup>	7200	3250	—	****	—	****	—
315A-2	EDM5412V ~ EDM5462V	375,450				****	—	****	—
400A	EDM6851V	750但し1200min <sup>-1</sup>	8100	6200	—	****	—	****	—

注記) \*\*\*\*部の数値につきましては問い合わせ下さい。

NOTE) For the figure in \*\*\*\* position contact us.

## 2. 据付 Mounting Arrangement.

標準 Standard			準標準 Available on Request		
記号 Symbol	形状 Outline	枠番 Frame Size	記号 Symbol	形状 Outline	枠番 Frame Size
B3		90A 100A, 100B 112A, 112B 132A, 132B 160A, 160B-1, 160B-2 180A, 180B-1, 180B-2 200A, 200B 250A-1, 250A-2 315A-1, 315A-2 400A	B5		90A 100A, 100B 112A, 112B 132A, 132B 160A, 160B-1, 160B-2 180A, 180B-1, 180B-2 200A, 200B 250A-1, 250A-2 315A-1, 315A-2 400A
B6			V1		
B7			V3		
B8					
V5		90A 100A, 100B 112A, 112B 132A, 132B	V5		160A, 160B-1, 160B-2 180A, 180B-1, 180B-2 200A, 200B 250A-1, 250A-2 315A-1, 315A-2 400A
V6			V6		

## 3. 標準Vベルト・Vプーリ適用表 Standard V belt · Narrow type V belt application

電動機出力軸に加わる荷重を小さくする為に、下図のようにVプーリのリム端面が軸段付部と同一面になるように取付けて下さい。

To minimize the load to motor's output shaft, rim face of V pulley and step part of shaft shall be installed with same level like a following picture.

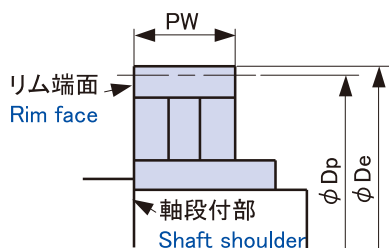

出力 Motor Output (kW)	標準Vベルト Standard V Belt					細幅Vベルト Narrow Type V Belt				
	Vベルト V Belt		Vプーリ V Pulley		定格回転速度 Rated Rotating Speed (min <sup>-1</sup> )	Vベルト V Belt		Vプーリ V Pulley		定格回転速度 Rated Rotating Speed (min <sup>-1</sup> )
	形式 Type	本数 Qty	Dp (mm)	PW (mm)		形式 Type	本数 Qty	Dp (mm)	PW (mm)	
2.2	A	2	100	35	1800~2400	3V	2	75	27.7	1800~2400
3.7	A	3	112	50	1800~2400	3V	2	100	27.7	1800~2400
5.5	B	3	125	63	1800~2400	3V	3	100	38	1800~2400
7.5	B	3	150	63	1800~2400	3V	3	125	38	1800~2400
11	B	4	160	82	1800~2400	3V	4	125	48.3	1800~2400
15	B	5	170	101	1800~2400	3V	6	125	68.9	1800~2400
18.5	B	5	200	101	1800~2400	3V	6	140	68.9	1800~2400
22	B	5	224	101	1800~2400	3V	6	160	68.9	1800~2400
30	C	5	224	136	1800~2400	5V	4	180	77.9	1800~2400
37	—	—	—	—	—	5V	4	200	77.9	1800~2400
45	C	6	265	161.5	1800~2400	5V	4	224	77.9	1800~2400
55	C	7	265	187	1800~2400	5V	5	224	95.4	1800~2400
65	—	—	—	—	—	5V	5	250	95.4	1800~2400
75	C	8	315	212.5	1800~2400	5V	6	250	112.9	1800~2400
90	—	—	—	—	—	5V	6	280	112.9	1800~2400
110	—	—	—	—	—	5V	6	315	112.9	1800~2400
132	—	—	—	—	—	5V	8	315	147.6	1800~2400
160	—	—	—	—	—	5V	9	315	165.1	1800~2400
200	—	—	—	—	—	5V	10	355	182.5	1800~2150
250	—	—	—	—	—	5V	12	400	217.5	1800~1900

## 5) 東洋EDモータ断面図 TOYO ED Motor cross section

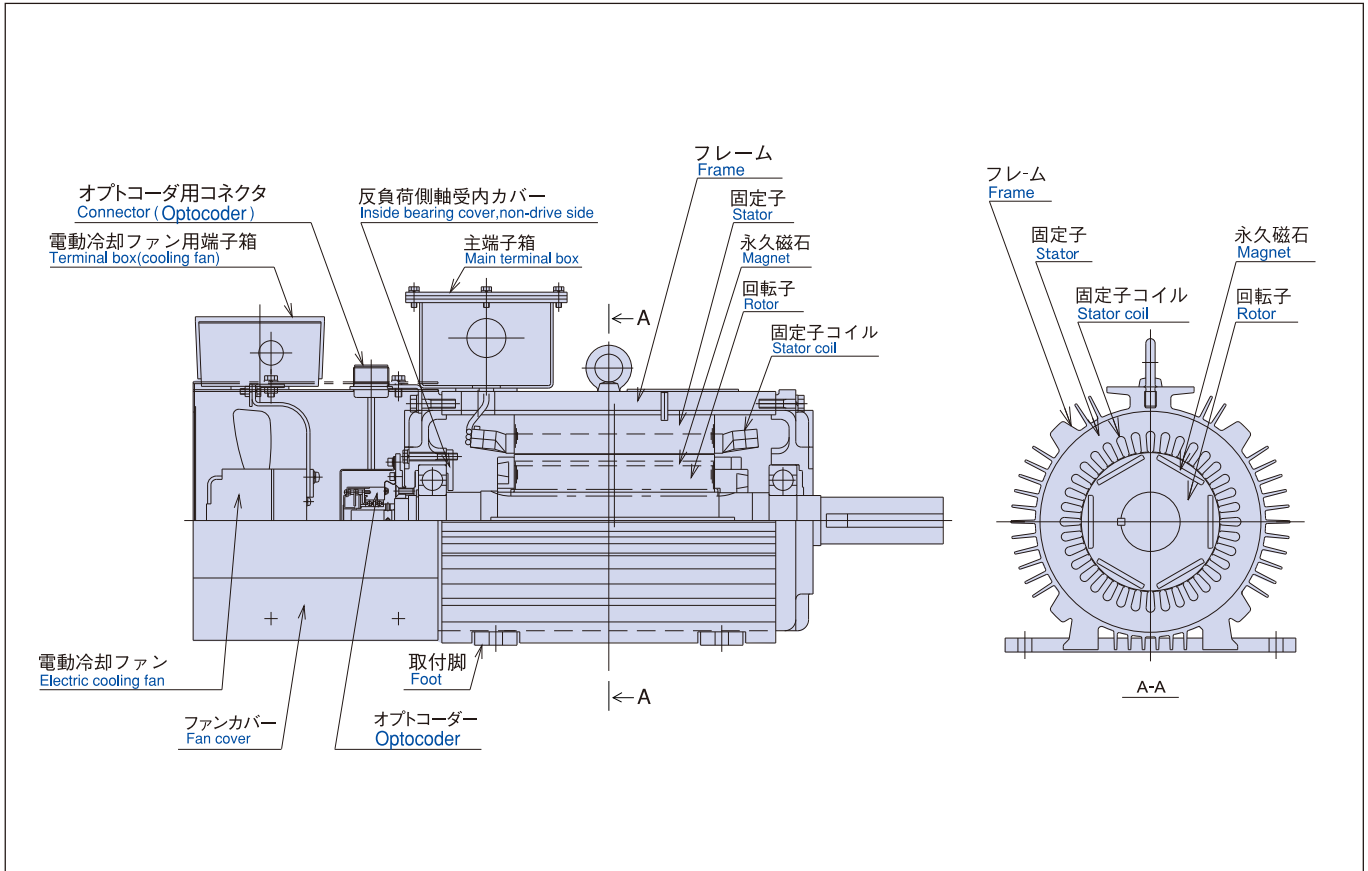

## 6) スライドレール (オプション) Slide rail (Option)

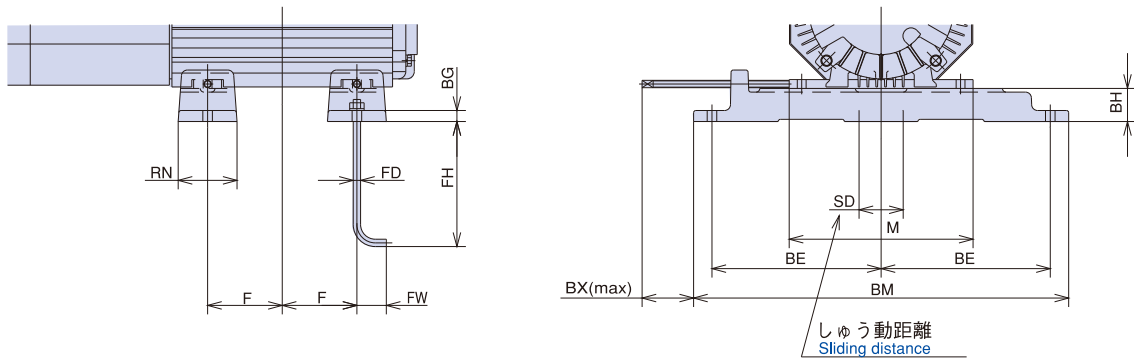

スライドレール番号 Slide rail No.	モータ枠番 Motor's frame size	外形寸法 Outline dimensions (mm)													スライドレール 概略質量 Slide rail's approx weight (kg)
		BE	BH	BM	BG	M	BX	FD	FH	FW	RN	F	SD		
SR-0	90A	200	40	450	15	180	45	M10	130	40	60	62.5	60	7	
SR-1	100A, 100B	230	45	510	15	220	85	M10	170	40	80	79.5	60	11	
	112A, 112B					250	100					101.5			
SR-2	132A	310	55	670	20	300	55	M12	160	50	100	127	80	22	
	132B											139.5			
SR-3	160A, 160B-1, 160B-2	320	60	700	25	350	65	M16	355	63	110	159	80	32	
SR-4	180A, 180B-1, 180B-2	420	70	900	28	370	60	M20	455	80	130	203	120	58	
SR-5	200A	510	75	1080	30	460	100	M20	445	80	150	254	160	60	
SR-6	200B, 250A-1, 250A-2	575	90	1220	35	520	70	M24	560	100	160	315	140	100	

# Water-cooled ED MOTER

水冷式EDモータ

Water-cooled ED Motor

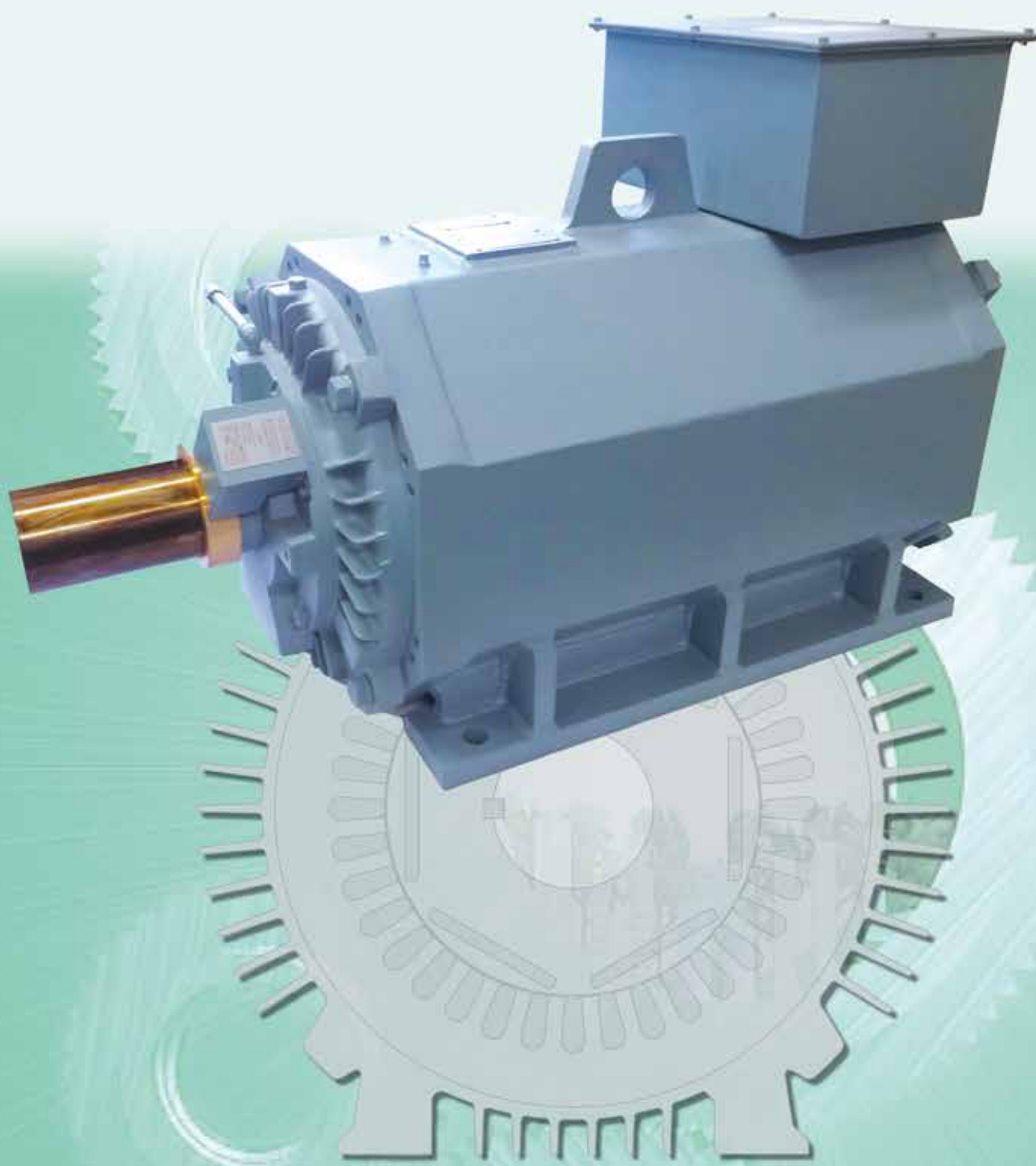

# Water-cooled ED MOTER

## 1) 水冷式EDモータの特長 Water-cooled ED motor feature

- ・ 周囲環境に配慮した低騒音性  
(標準EDモータに対して5~10dB(A)低減)  
Environmentally friendly low noise levels: 5 to 10 dB (A) less than the standard ED motor
- ・ 標準EDモータと比較してさらに小型化  
More compact than the standard ED motor
- ・ ファンモータがないため塵埃が舞わず、製造中の製品を汚しません  
No fan motor, and therefore, no dust gets blown around that would otherwise contaminate the product during production
- ・ ファンモータがないため塵埃のある環境でも長寿命を維持  
No fan motor, so it can be used for a long time in dusty environments
- ・ 通常の空冷式EDモータと取り付け互換あり  
Compatible mounting of that of conventional air-cooled ED motors
- ・ 工業用水道水の使用が可能\*  
Can use industrial water\*

\* 国外での使用など、水に汚れ等がある場合、また冷却水に凍結する恐れがある場合は、別置の熱交換器をご使用下さい。

\* Water in certain countries might be too dirty for use. Also, cold water could lead to freezing. Use a heat exchanger for such conditions.

## 2) 仕様 Specification

		標準仕様 Standard	準標準仕様 Available on Request
1	定格事項 Rating	極数 No. of pole	6極 6 Poles (190V級は90kWまで)
		出力 Output	18.5~750kW(190V class is up to 90kW)
	電圧 Voltage	190/380V	
	定格基底回転速度 Rated Rotating speed	1800min <sup>-1</sup> 出力一定範囲は基底回転に対し1:1.33 Output constant range is 1:1.33 against basic rotating speed.	1500min <sup>-1</sup> /1200min <sup>-1</sup> 回転速度、定出力範囲の変更についてはお問い合わせ下さい。
	時間定格 Time rating	連続 Continuous	Please refer to us for change of rotation speed or power constant range.
2	外被 Enclosure	保護形式 Protection	IP44(全閉防まつ形) IP44(Totally enclosed splash proof)
		冷却 Cooling	フレーム水冷却・他力形 Frame water-cooled, other power format
3	騒音レベル Noise level	標準空冷式EDモータに対して5~10dB(A)程度低減 5 to 10 dB(A) better than a standard air-cooled ED motor	

注1) 本表以外の仕様はP5標準仕様に準じますが、詳細は別途お問い合わせ下さい。

注2) 工業用水道の使用が可能です。国外での使用など水に汚れ等がある場合、冷却水が凍結する恐れのある場合は、別置の熱交換器をご使用下さい。

Note 1) For specifications other than outlined in this table, refer to the standard specifications on page 5 and contact Toyo Denki for details.

Note 2) Although industrial water can be used, water in certain countries might be too dirty for use. Also, cold water could lead to freezing. Use a heat exchanger for such conditions.



### 3) 出力・枠番適用・定格電流

## Application Between Output(kW), Rotating Speed(min<sup>-1</sup>)& Frame Size, Full Load Current(A)

枠番 Frame size		形 Type	
□□ A / □□ A		□□ A / □□ A	
190V最高速度電流/190V基底速度電流 Top / Base speed Current at 190V		380V最高速度電流/380V基底速度電流 Top / Base speed Current at 380V	

出力一定速度 Power constant speed	標準仕様 Standard		準標準仕様 Available on Request					
	2400~1800min <sup>-1</sup>		2000~1500min <sup>-1</sup>		1600~1200min <sup>-1</sup>			
トルク一定範囲 Torque constant range	1800~0min <sup>-1</sup>		1500~0min <sup>-1</sup>		1200~0min <sup>-1</sup>			
基底速度 Base speed	1800min <sup>-1</sup>		1500min <sup>-1</sup>		1200min <sup>-1</sup>			
定格出力 Rated output	190V		380V		190V		380V	
18.5kW	—		—		132A EDM2221W			
	—	—	—	—	62.9A/65.9A	31.5A/32.8A		
22kW	—		132A EDM2221W		132B EDM2231W			
	—	—	74.1A/79.4A	37.1A/39.5A	72.7A/80.9A	36.4A/40.3A		
30kW	132A EDM2221W		132B EDM2231W		160A EDM2761W			
	97.9A/114A	48.9A/56.8A	98.9A/110A	49.2A/54.5A	95.9A/117A	47.9A/58.2A		
37kW	132B EDM2231W		160A EDM2761W		160A EDM2761W			
	121A/134A	60.6A/66.8A	119A/146A	59.5A/68.4A	119A/143A	59.3A/71.2A		
45kW	160A EDM2761W		160A EDM2761W		160A EDM2771W			
	146A/164A	72.6A/81.9A	144A/175A	71.0A/83.5A	144A/169A	71.8A/84.1A		
55kW	160A EDM2761W		160A EDM2761W		160B-2 EDM2781W			
	176A/202A	88.0A/101A	176A/202A	88.0A/101A	176A/198A	88.1A/98.7A		
75kW	160B-1 EDM2772W		160B-2 EDM2781W		180A EDM3141W			
	240A/270A	120A/135A	239A/280A	119A/140A	239A/269A	119A/134A		
90kW	160B-2 EDM2781W		180A EDM3141W		180B-1 EDM3151W			
	287A/325A	143A/162A	286A/322A	143A/161A	286A/340A	143A/177A		
110kW	180A EDM3141W		180B-1 EDM3151W		180B-2 EDM3161W			
	—	175A/203A	—	174A/197A	—	174A/196A		
132kW	180B-1 EDM3151W <sup>(※1)</sup>		180B-2 EDM3161W		200A EDM3541W			
	—	—/253A	—	209A/240A	—	208A/235A		
160kW	180B-2 EDM3161W <sup>(※1)</sup>		200B EDM3561W		200B EDM3551W			
	—	—/294A	—	258A/278A	—	252A/290A		
200kW	200B EDM3551W <sup>(※1)</sup>		200B EDM3551W		200B EDM3561W			
	—	—/366A	—	328A/336A	—	314A/367A		
250kW	200B EDM3561W <sup>(※1)</sup>		250A-1 EDM4331W		250A-1 EDM4331W			
	—	—/441A	—	393A/451A	—	392A/422A		
315kW	250A-1 EDM4331W <sup>(※1)</sup>		315A-2 EDM5422W		315A-1 EDM5411W			
	—	—/599A	—	503A/581A	—	489A/598A		
375kW	250A-2 EDM5412W <sup>(※1)</sup>		315A-2 EDM5422W <sup>(※2)</sup>		315A-1 EDM5451W			
	—	—/600A	—	590A/688A	—	597A/652A		
400kW	—		—		315A-1 EDM5451W			
	—	—	—	—	—	631A/696A		
450kW	315A-2 EDM5452W <sup>(※1)</sup>		315A-2 EDM5462W <sup>(※2)</sup>		315A-2 EDM5462W <sup>(※3)</sup>			
	—	—/707A	—	700A/781A	—	701A/840A		
750kW	—		—		400A EDM6851W <sup>(※4)</sup>			
	—	—	—	—	—	—/1203A		

(※1) トルク一定制御のみ (1800min<sup>-1</sup>まで) です。

(※2) 出力一定範囲は1800~1500min<sup>-1</sup>です

(※3) 出力一定範囲は1500~1200min<sup>-1</sup>です。

(※4) トルク一定制御のみ (1200min<sup>-1</sup>まで) です。

\*1. Only torque constant control, up to 1800min<sup>-1</sup>.

\*2. Power constant range is 1800-1500min<sup>-1</sup>.

\*3. Power constant range is 1500-1200min<sup>-1</sup>.

\*4. Only torque constant control, up to 1200min<sup>-1</sup>.

# Water-cooled ED MOTER

## 3) 外形寸法 (脚取付形) Dimensions (Foot mounting)

形式・Type 枠番 Frame Size	図・番号 Fig. Symbol	電動機本体 General																
		C	D	E	F	G	H	J	K1	K2	K3	L	M	N	R	XB	Z	KD
EDM2221W 132A	A	132 $\pm 0.5$	264	127	127	17	389	70	65	65	32.5	641.5	300	319	345	108	14.5	51
EDM2231W 132B		132 $\pm 0.5$	264	127	139.5	17	389	70	65	65	32.5	681.5	300	344	357.5	108	14.5	51
EDM2761W 160A	B	160 $\pm 0.5$	355	139.5	159	20	501	80	85	85	42.5	797	350	403	467	168	18.5	80
EDM2771W 160A		160 $\pm 0.5$	355	139.5	159	20	501	80	85	85	42.5	797	350	403	467	168	18.5	80
EDM2772W 160B-1		160 $\pm 0.5$	355	139.5	159	20	501	80	85	85	42.5	824	350	403	467	168	18.5	80
EDM2781W 160B-2		160 $\pm 0.5$	355	139.5	159	20	501	80	85	85	42.5	867	350	403	467	168	18.5	80
EDM3141W 180A		180 $\pm 0.5$	355	159	203	20	523	75	100	100	50	891	370	506	511	168	24	80
EDM3151W 180B-1		180 $\pm 0.5$	355	159	203	20	523	75	100	100	50	961	370	506	581	208	24	80
EDM3161W 180B-2		180 $\pm 0.5$	355	159	203	20	523	75	100	100	50	1041	370	506	581	208	24	80
EDM3541W 200A		200 $\pm 0.5$	404	203	254	32	568	80	114	114	50	1158	460	608	592	168	24	80
EDM3551W 200B		200 $\pm 0.5$	404	228.5	315	32	568	100	122	120	50	1253	520	732	715	225	28	80
EDM3561W 200B		200 $\pm 0.5$	470	228.5	315	32	618	100	122	120	50	1253	520	732	715	225	28	102
EDM4331W 250A-1	C	250 $\pm 0.5$	514	228.5	315	32	712	100	110	110	50	1249	520	730	715	225	28	102
EDM5411W 315A-1		315 $\varnothing$	640	305	355	32	858	125	130	130	55	1460	680	820	781	251	28	—
EDM5451W 315A-1		315 $\varnothing$	640	305	355	32	858	125	130	130	55	1460	680	820	781	251	28	—
EDM5412W 315A-2		315 $\varnothing$	640	305	355	32	858	125	130	130	55	1500	680	820	781	251	28	—
EDM5422W 315A-2		315 $\varnothing$	640	305	355	32	858	125	130	130	55	1460	680	820	781	251	28	—
EDM5452W 315A-2		315 $\varnothing$	640	305	355	32	1275	110	130	130	55	2045	680	820	781	251	28	—
EDM5462W 315A-2		315 $\varnothing$	640	305	355	32	858	125	130	130	55	1460	680	820	781	251	28	—
EDM6851W 400A		400 $\varnothing$	764	375	450	38	1017	180	150	150	70	1731	830	1040	940	280	35	—

1. 寸法を変更する場合があります。ご注文の際には改めてご承認用寸法図を提出いたします。
2. スライドレールが必要な場合は、別途ご要求下さい。

軸端部 Shaft Extension (mm)								軸受 Bearing	概略 質量 Approx Weight (kg)	GD <sup>2</sup> Rotor Inertia (kgf·m <sup>2</sup> )
P	Q	QR	S	T	U	W	ED	伝動側 Drive End		
								反伝動側 Non-Drive End		
Rc1/4	110	1.5	55m6	10	6	16	84	6312ZZ/5K	150	0.29
								6312ZZ/5K		
Rc1/4	110	1.5	55m6	10	6	16	84	6312ZZ/5K	175	0.33
								6312ZZ/5K		
Rc1/4	140	1.0	60m6	11	7	18	110	NU313	245	0.46
								6312ZZ/5K		
Rc1/4	140	1.0	60m6	11	7	18	110	NU313	285	0.58
								6312ZZ/5K		
Rc1/4	140	1.0	75m6	12	7.5	20	110	NU316	295	0.62
								6312ZZ/5K		
Rc1/4	140	1.0	75m6	12	7.5	20	110	NU316	325	0.69
								6312ZZ/5K		
Rc1/4	140	1.0	75m6	12	7.5	20	110	NU316	348	1.02
								6315ZZ/5K		
Rc1/4	170	1.0	95m6	14	9	25	135	NU320	400	1.23
								6315ZZ/5K		
Rc1/4	170	1.0	95m6	14	9	25	135	NU320	465	1.46
								6315ZZ/5K		
Rc1/4	170	1.0	95m6	14	9	25	135	NU320	610	2.34
								6315ZZ/5K		
Rc1/4	175	-	110m6	16	10	16	165	NU324	750	2.93
								6318		
Rc1/4	175	-	110m6	16	10	28	165	NU324	800	3.24
								6318		
Rc3/8	175	-	110m6	16	10	28	165	NU324	1100	6.04
								6318		
Rc1/2	175	-	110m6	16	10	28	165	6324	1600	13.9
								6318		
Rc1/2	175	-	110m6	16	10	28	165	6324	1840	17.4
								6318		
Rc1/2	175	-	110m6	16	10	28	165	6324	1700	13.9
								6318		
Rc1/2	175	-	110m6	16	10	28	165	6324	1680	15.0
								6318		
Rc1/2	175	-	110m6	16	10	28	165	6324	1990	18.5
								6318		
Rc1/2	175	-	110m6	16	10	28	165	6324	2050	19.7
								6318		
Rc3/4	210	-	120m6	18	11	32	200	6326	3550	50.6
								6324		

1.Dimension may be changed without pre-advise.At the time of order from customer,dimension drawing for approval is supplied newly.  
2.In case of need of slide rail, require us.separately.

# Water-cooled ED MOTER

図A(132A, 132B) Fig.A(132A, 132B)

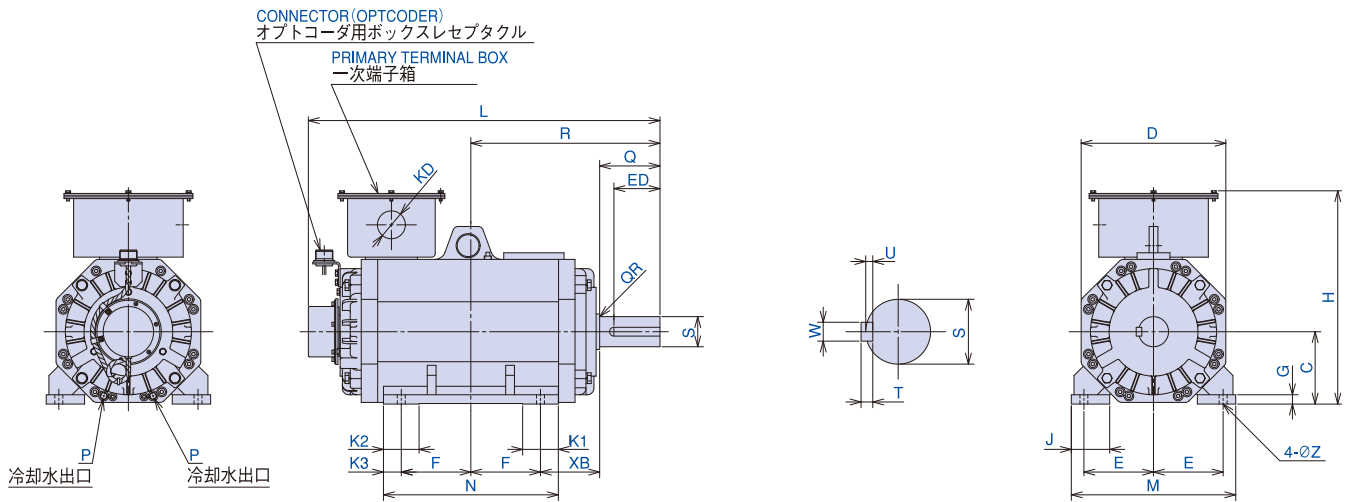

図B(160A~200A) Fig.B(160A~200A)

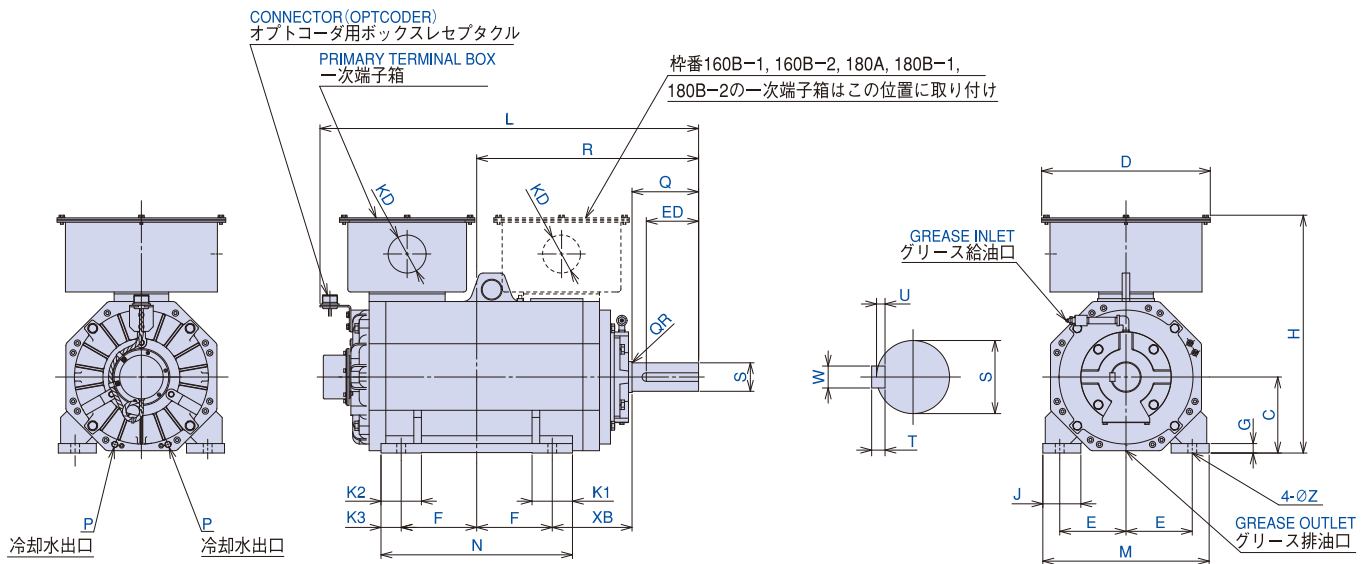

図C(200B~400A) Fig.C(200B~400A)

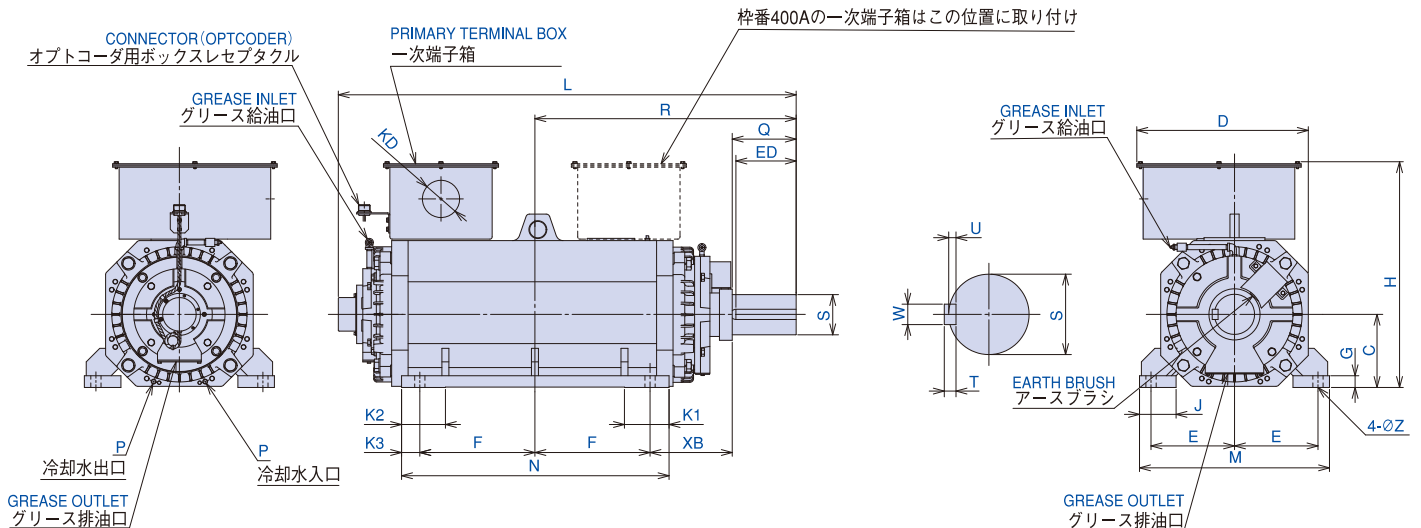

## EDモータ適用上の注意

- 1) 商用電源での直入始動運転は出来ません。  
このような用途でお使いの場合には誘導電動機をご使用下さい。
- 2) 電源を切った状態でもモータが回転中は、モータ端子に電圧が発生していますので手を触れないで下さい。
- 3) 電源を切った状態でモータが電源を負荷によりモータ定格回転数以上の速度で廻される可能性のある用途には適用しないで下さい。
- 4) モータに内臓している温度センサはモータガードリレーと組み合わせて使用し、温度異常検出にてモータの運転を停止させて下さい。
- 5) 規定温度（40℃）以上の環境でご使用の場合にはモータの出力のデレーティングが必要になります。  
このような場合は弊社にご相談下さい。
- 6) 1台のインバータで複数のEDモータを運転することは出来ません。  
このような運転を必要とされる場合には、弊社UFモータ（誘導電動機）をご使用下さい。
- 7) 出力一定制御でご使用の場合には必ずインバータとモータの間に電磁接触器を設け、停電やインバータおよびモータの異常時にインバータを停止すると共に電磁接触器をOFFし回路を遮断して下さい。

## Point to be attended on use of ED motor

- 1) Direct-on-line starting by commercial power is not available. Please use induction motors when using it by such a usage.
- 2) Don't touch motor terminal even in the state after turning off of the power, since voltage is generated while motor is running.
- 3) Don't use motor for the application which has possibility of running (by load) of higher speed than motor rating speed, in the state of powering off.
- 4) Please combine with Motor guard relay, use, and stop drive of motor about temperature sensor built into motor because of temperature abnormality detection.
- 5) Derating of motor output is needed when using it in environment more than regulated temperature (40℃)  
For this case, please consult our company.
- 6) Two or more ED motors cannot be driven in one inverter. Please use our company UF motor (induction motors) when such a drive is needed.
- 7) Magnetic contactor is installed between inverter and motor whenever using it by power constant control, and please stop inverter when power failure, inverter or motor are abnormal, turn off magnetic contactor, and intercept circuit.



## ご使用に当たって、安全上の注意事項 SAFETY PRECAUTIONS ON USE

ご使用前に「取扱説明書」をよくお読みの上、正しくご使用ください。

EDモータは人命にかかわるような状況下で使用される機器あるいはシステムに用いられることを目的として設計、製造されたものではありません。

本資料記載の製品を乗用移動体用、医療用、航空宇宙用、原子力制御用、海底中継機器あるいはシステムなど、特殊用途にご検討の際には当社の営業窓口までご照会下さい。

本製品は厳重な品質管理のもとに製造しておりますが、インバータが故障することにより人命にかかわるような設備および重大損失の発生が予測される設備への適用に際しては、重大事故にならないよう安全設備を設置して下さい。

この製品は電気工事が必要です。電気工事は専門家が行って下さい。

Before using the product, please read [Instruction Manual] carefully.

ED Motor made by us is not designed and manufactured use in any equipment or system that is applied in an environment affecting human life. If you intend to use the product for specific applications such as passenger modile, medical, aerospace, nuclear control or submarine relay equipment or system, please contact us.

This product was manufactured under strict quality control however, safety device or system must be used with this product when applied to any facility in which failure of the Inverter to perform can be reasonably expected to cause a problem critical to human life or its loss.

This product requires electrical work, which must be done by specialists.



 **東洋電機製造株式会社**

<http://www.toyodenki.co.jp/>

本社 東京都中央区八重洲一丁目4-16(東京建物八重洲ビル) 〒103-0028  
産業事業部 TEL.03-(5202)-8132~6 FAX.03-(5202)-8150

**TOYODENKI SEIZO K.K.**

<http://www.toyodenki.co.jp/>

HEAD OFFICE: Tokyo Tatemono Yaesu Bldg, 1-4-16 Yaesu,  
Chuo-ku, Tokyo, Japan ZIP CODE 103-0028  
TEL: +81-3-5202-8132~6  
FAX: +81-3-5202-8150

サービス網  
**東洋産業株式会社**

<http://www.toyosangyou.co.jp>

本社 東京都千代田区東神田 1丁目10-6 (幸保第二ビル) 〒101-0031  
TEL.03 (3862) 9371 FAX.03 (3866) 6383

本資料記載内容は、予告なく変更することがあります。ご了承ください。

A part of specification and dimension is subject to change without notification in advance because of improvement of product, therefore your understanding is requested.